

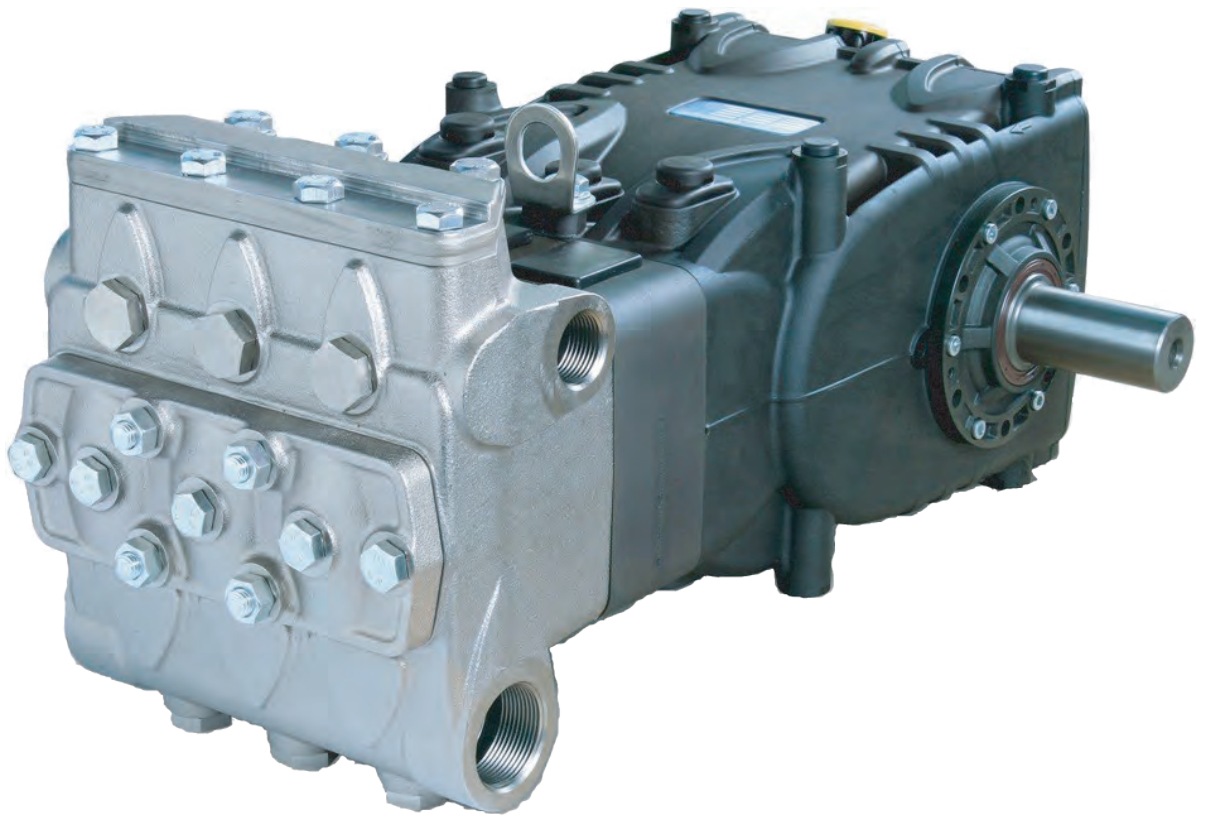



FORDIA®

ELEPUMP

Serie KF-50M



Manuale di riparazione
Repair Manual
Manuel de réparation
Reparaturanleitung
Manual de reparación
Manual de reparação
Руководство по ремонту

Table of Contents

1 INTRODUCTION	15
1.1 DESCRIPTION OF SYMBOLS.....	15
2 REPAIR GUIDELINES	15
2.1 REPAIRING MECHANICAL PARTS.....	15
2.1.1 <i>Disassembly of mechanical parts</i>	15
2.1.2 <i>Reassembly of mechanical parts</i>	16
2.1.3 <i>Disassembly / Reassembly of bearings and shims</i>	16
2.2 REPAIRING HYDRAULIC PARTS.....	18
2.2.1 <i>Valve units</i>	18
2.2.1.1 <i>Dismantling the valve units</i>	18
2.2.1.2 <i>Reassembly</i>	18
2.2.2 <i>Wiper</i>	19
2.2.2.1 <i>Disassembly</i>	19
2.2.2.2 <i>Reassembly</i>	20
2.2.3 <i>Piston spacer unit</i>	21
2.2.3.1 <i>Disassembly</i>	21
2.2.3.2 <i>Reassembly</i>	21
2.2.4 <i>Piston seal</i>	21
2.2.4.1 <i>Disassembly</i>	21
2.2.4.2 <i>Reassembly</i>	22
2.2.5 <i>Cylinder</i>	22
2.2.5.1 <i>Disassembly</i>	22
2.2.5.2 <i>Reassembly</i>	23
3 COMPONENT TIGHTENING TORQUE	23
4 REPAIR TOOLS	24
4.1 VALVE SEAT ASSEMBLY / DISASSEMBLY TOOL MECHANICAL DRAWINGS.....	24

1 INTRODUCTION

This manual describes the instructions for repair of the KF50M pump family and should be carefully read and understood before any intervention on the pump. Proper pump operation and duration depend on the correct use and maintenance.

Interpump Group disclaims any responsibility for damage caused by negligence or failure to observe the standards described in this manual.

1.1 DESCRIPTION OF SYMBOLS

Read the contents of this manual carefully before each operation.



Warning Sign



Read the contents of this manual carefully before each operation.



Danger Sign

Wear protective goggles.



Danger Sign

Put on protective gloves before each operation.

2 REPAIR GUIDELINES



2.1 REPAIRING MECHANICAL PARTS

Mechanical parts must be repaired after the oil has been removed from the casing.

To remove oil, you must remove: the oil dipstick, pos. ① and then the plug pos. ②, Fig. 1.

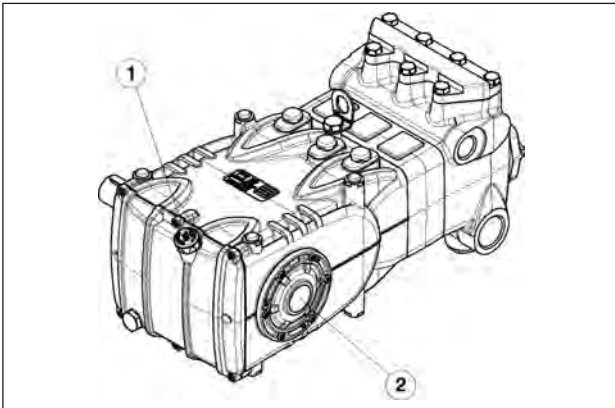

Fig. 1



The used oil must be placed in a suitable container and disposed of in special centres. It absolutely should not be discarded into the environment.

2.1.1 Disassembly of mechanical parts

The correct sequence is as follows:

A) Remove:

- the pump shaft tab
- the rear cover
- the con-rod cap
- the side covers using - for extraction 3 fully threaded M6 x 50 screws, inserting them in the threaded holes as indicated in Fig. 2.



Fig. 2

B) Push the piston guides forward with their con-rods to facilitate side extraction of the pump shaft. There are two reference points visible on the shaft, ③ as shown in Fig. 3 and in Fig. 3/a. These must be turned toward the operator to facilitate extraction.

Note: extraction of the piston guides depends on prior removal of the ceramic piston, the piston spacer and the relative spray hood.

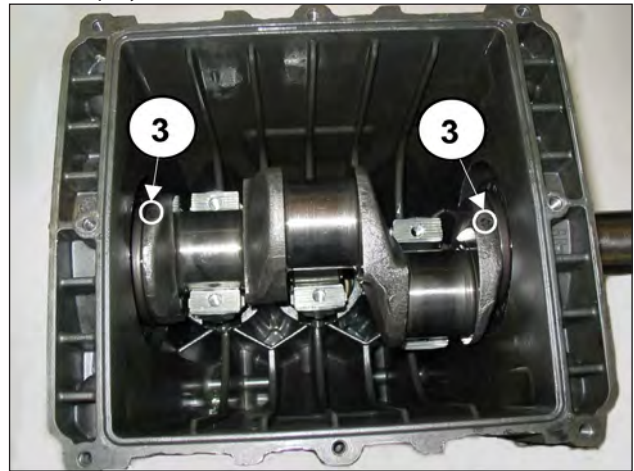

Fig. 3

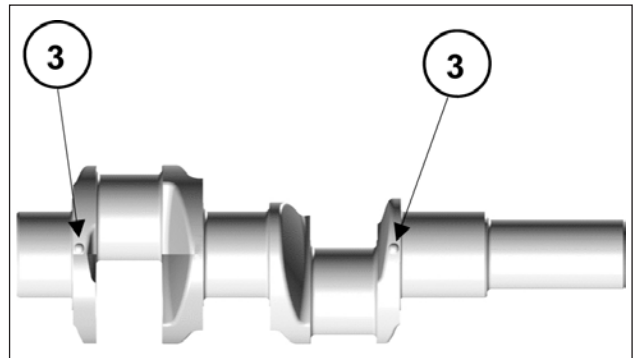

Fig. 3/a

C) Proceed with disassembly of the shaft seal rings and piston guides with common tools.

2.1.2 Reassembly of mechanical parts

After having checked that the casing is clean, you can proceed with assembly of the mechanical part by following these steps:

- A) Position the piston guide seal rings with the relative housings on the casing as indicated in Fig. 5/a, using the tool (code 27904900).
- B) Insert the pre-mounted piston guide/con-rod unit in the housing; to facilitate the following tightening of the con-rod cap, it is best to position the con-rod with the number easily visible. To facilitate shaft insertion without the tab, it is best to push the piston guide/con-rod unit as far down as possible, as per par. 2.1.1 point B and indicated in Fig. 4.



Fig. 4

- C) Before proceeding with side cover assembly, check lip seal conditions on the radial ring. If replacement is necessary, position the new ring using a tool (code 27904800) as shown in Fig. 5.

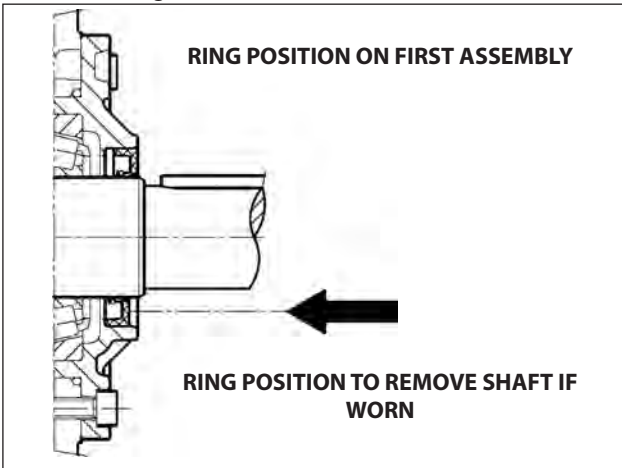

Fig. 5

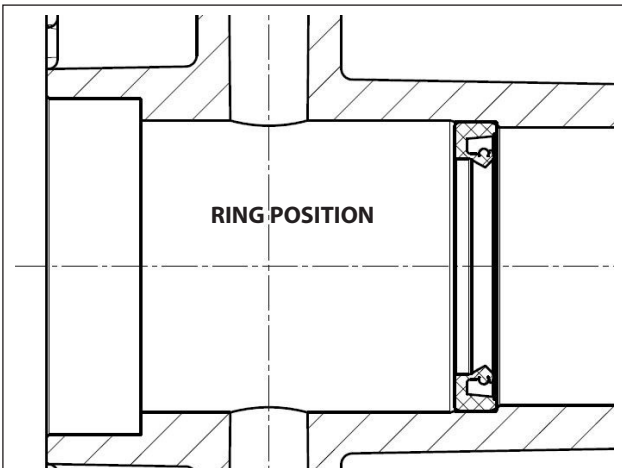

Fig. 5/a



If the shaft should present a diameter wear corresponding to the lip seal, to prevent grinding, position the ring in the second stroke as indicated in Fig. 5.

Before assembling the indicator side cover, ensure the presence of shim rings. To facilitate filling of the first section and relative press fitting of the covers on the casing, we recommend using 3 M6 x 40 screws, then complete the operation with supplied screws (M6x18) as shown in Fig. 6.



Fig. 6

- D) Mount the con-rod cap respecting the corresponding numbers and tighten respective screws at the same time (as indicated in Fig. 7), lubricating both the underhead and the threaded shank, proceed in three different steps:



1. Transition torque 6 - 8 Nm
2. Pre-tightening torque 10 - 15 Nm
3. Tightening torque 30 Nm



Fig. 7

- E) Mount the rear cover, positioning the dipstick hole upward.
- F) Insert oil in the casing as indicated in the **Use and maintenance manual**, par. 7.4.

2.1.3 Disassembly / Reassembly of bearings and shims

The type of bearings (taper roller) ensures the absence of axial clearance on the bend shaft. The shims are defined to meet this necessity.

For disassembly / reassembly and for any replacements, carefully observe the following directions:

A) Disassembly / Reassembly of the bend shaft without replacement of the bearings

After having removed the side covers as indicated in par. 2.1.1, check the conditions of the rollers and their relative tracks. If all parts are in good condition, clean the components carefully with a degreaser and redistribute lubricant oil uniformly. The previous shims can be reused, taking care to insert them only under the indicator side cover.

Once the complete unit is mounted (Indicator side flange + shaft + motor side flange), check that the rotation torque of the shaft - with the con-rod disconnected - is a minimum 4 Nm, Max 7 Nm.

To transition the two side covers closer to the casing, it is possible to use 3 M6x40 screws for the first positioning phase as indicated in Fig. 6 and the screws provided for final fastening.

Shaft rotation torque (with the con-rod connected) should not exceed 8 Nm.

B) Disassembly / Reassembly of the bend shaft with replacement of the bearings

After having removed the side covers as indicated in par. 2.1.1, remove the outer ring nut of the bearings from the relative covers and the inner ring nut with the remaining part of the bearing from the two ends of the shaft by means of a normal "pin punch" or a similar tool as indicated in Fig. 8 and Fig. 9.



Fig. 8



Fig. 9

The new bearings can be mounted cold with a press or rocker, supporting it on the lateral surface of the ring nuts involved in press fitting with the rings. The press fitting operation can be facilitated by heating the involved parts to a temperature between 120°C - 150°C (250°F - 300°F), ensuring that the ring nuts fit fully into their seats.



Never exchange the parts of the two bearings.

The shim pack must be redefined as follows:

- Insert the bend shaft in the casing, checking that the PTO shank comes out from the provided side.
- Fasten the PTO side flange to the casing, taking care to set the lip seal as indicated in par. 2.1.2 point C.
- Bring the indicator side flange closer as in par. 2.1.2.
- With the help of a thickness gauge (see Fig. 10):



Fig. 10

Proceed to determine the shim pack, using the table below:

Detected Measurement	Shim Type	# pieces
From: 0.05 to: 0.10	/	/
From: 0.11 to: 0.20	0.1	1
From: 0.21 to: 0.30	0.1	2
From: 0.31 to: 0.35	0.25	1
From: 0.36 to: 0.45	0.35	1
From: 0.46 to: 0.55	0.35 0.10	1
From: 0.56 to: 0.60	0.25	2
From: 0.61 to: 0.70	0.35 0.25	1



Fig. 11

- Insert shims under the indicator side cover (see Fig. 11), fastening it to the cover with the respective screws, checking that the resistant torque is between 4 Nm and 7Nm.
- If the torque is correct, proceed with connecting the con-rods to the bend shaft, otherwise redefine the shims repeating the operations from point C.

2.2 REPAIRING HYDRAULIC PARTS

2.2.1 Valve units

2.2.1.1 Dismantling the valve units

Operations are limited to inspection or replacement of valves, if necessary.

Proceed as follows to extract valve units:



Fig. 12



Fig. 12/a



Fig. 12/b

- Unscrew the 12 M12x35 screws and the 4 M12 nuts fastening the valve cover and the front cover, then remove the covers (Fig. 12).
- Remove the valve plugs by means of an M12 extractor hammer (Fig. 12/a).
- Extract the balls using a magnet or other tool (Fig. 12/b).
- Move the suction and outlet valve housings using the tool code 27922400 (see mechanical drawings in par. 4.1) as indicated in Fig. 13, Fig. 13/a and Fig. 13/b.



Before working as per point D, make sure that the piston is at Bottom Dead Centre.



Fig. 13



Fig. 13/a



Fig. 13/b

2.2.1.2 Reassembly



Pay particular attention to the conditions of the various components and replace if necessary. However, an indication of estimated component replacement intervals is present in the table in Fig. 14 in chapter 11 of the **Use and maintenance manual**. It is plausible to think that the state of wear of the components will be strongly correlated with the type of fluid and the percentage of the presence of solid residues.

It is strongly advised to replace the O-Rings on the valve caps at each inspection



Before repositioning the valve seats, thoroughly clean and dry the relative housings in the head as shown in Fig. 14.

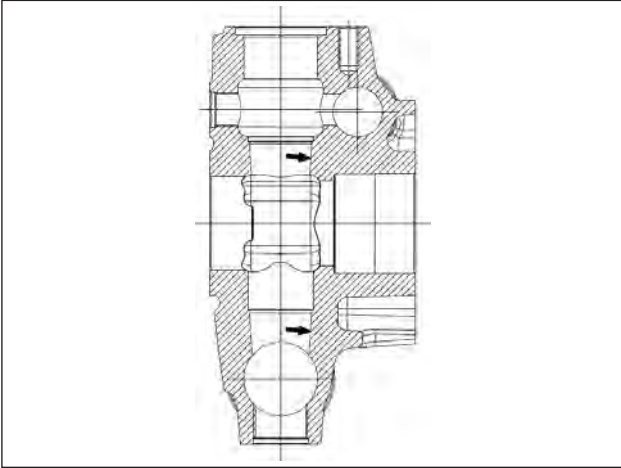

Fig. 14

To reassemble the various components, perform the operations listed above in reverse order to par. 2.2.1.1. In summary:

Assemble the suction and outlet valve seats using the buffer ① code 27702200 (see mechanical drawings in par. 4.1), ensuring that the tapered surfaces of said seats are locked in the tapered seats present on the head (Fig. 15 and Fig. 16). Now position the ball in the seat (Fig. 16/a), reassemble the valve caps and, at the front, reposition the valve covers. At the front, calibrate the respective M12x35 screws and M12 nuts with a torque wrench as indicated in chapter 3.



Fig. 15

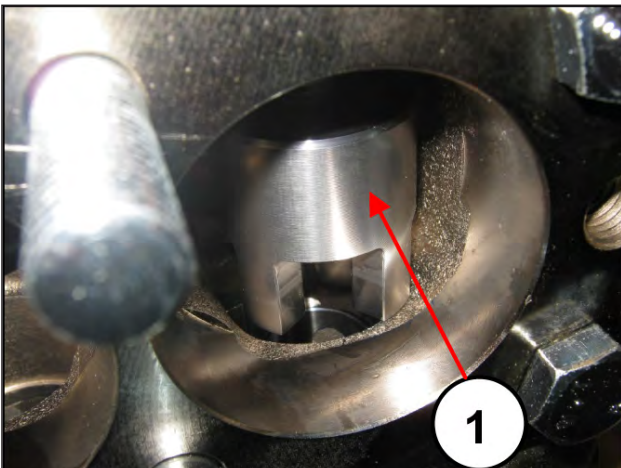

Fig. 16



Fig. 16/a

2.2.2 Wiper

2.2.2.1 Disassembly

Wiper replacement is necessary whenever bentonite leaks are detected from the second drainage chamber present between the spacer and the pump casing (Fig. 17). However, an indication of estimated component replacement intervals is present in the table in Fig. 14 in chapter 11 of the **Use and maintenance manual**.

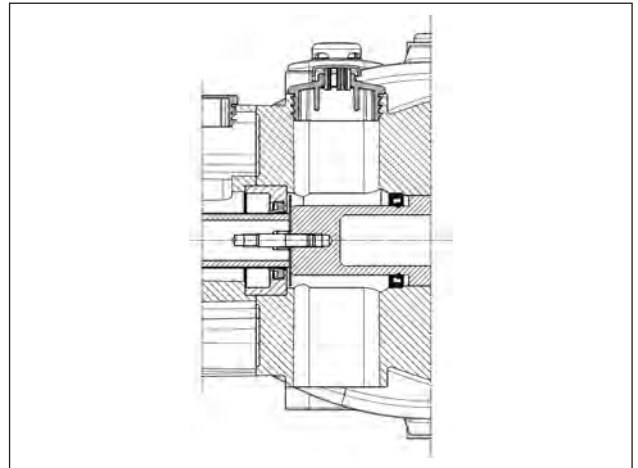

Fig. 17

A) Remove the front cover as indicated in Fig. 17/a and unscrew the M12 screws as indicated in Fig. 17/b.



Fig. 17/a



Fig. 17/b

- B) Remove the head and the head spacer from the pump casing.
- C) Extract the wiper support (Fig. 18) and remove the wiper using a simple tool as indicated in Fig. 18/a, taking care not to damage the seat. If necessary, remove the piston spacer (pos. ①), before extracting the wiper support (see par. 2.2.3.1).

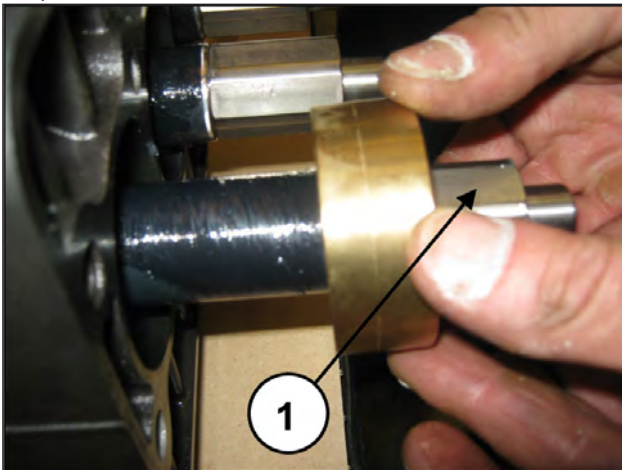

Fig. 18



Fig. 18/a

2.2.2.2 Reassembly

To replace the wiper, proceed as follows:

- A) Assemble the wiper in the housing on the support (Fig. 19), using a buffer as necessary and taking care not to damage the seal lip.



Fig. 19

- B) Reposition the wiper support with lubrication on the bush (Fig. 20), in the casing seat (Fig. 20/a). If removed, replace the piston spacer unit with bush lubrication after assembling the wiper support (see par. 2.2.3.2). Take care not to damage the seal lip.



Fig. 20

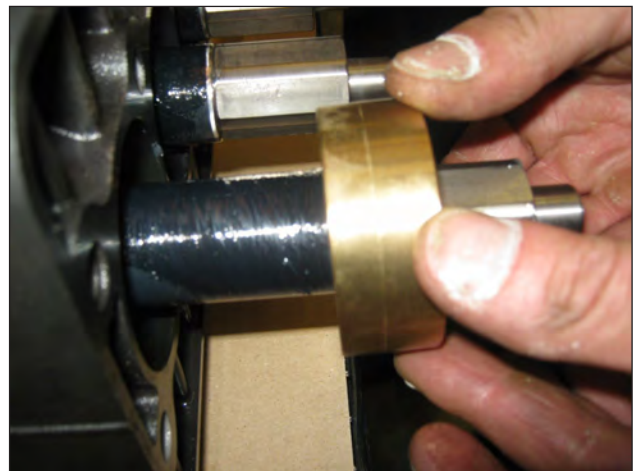

Fig. 20/a

- C) Reposition the head spacer and the head on the casing.
- D) Fasten the head, tightening the 4 M12 screws and then replace the front cover.

For the values of the torques and tightening sequences follow the instructions contained in chapter 3.

2.2.3 Piston spacer unit

2.2.3.1 Disassembly

The piston spacer unit does not require any routine maintenance. Maintenance is limited to visual checks only. Proceed as follows to extract the unit:

- A) After having removed the head and the head spacer, free the units as indicated in Fig. 21.

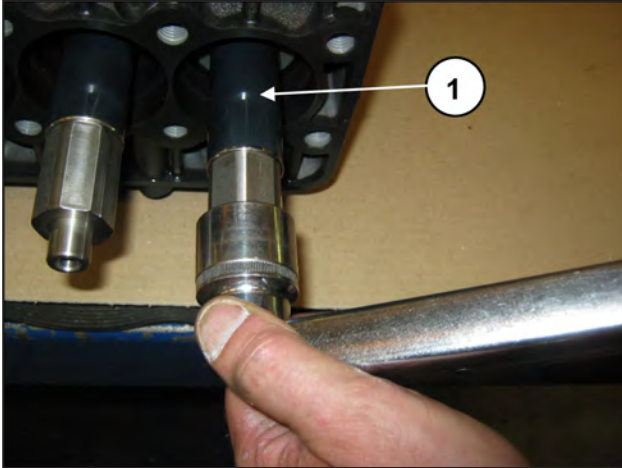

Fig. 21

- B) Check and verify their conditions, replace if necessary. Check and verify the conditions of the bushes assembled on the spacer (Fig. 21, pos. ①); replace them if necessary.

2.2.3.2 Reassembly

- A) Fit the bush on the spacer (Fig. 22) and tighten the unit on the piston guide rod (Fig. 22/a).



Fig. 22



Fig. 22/a



In the event that replacement is being carried out with the wiper already assembled, lubricate the bush and take care, during insertion, not to damage the wiper seal lip.

For the tightening torques, follow the instructions in chapter 3.

2.2.4 Piston seal

2.2.4.1 Disassembly

Piston seal replacement is necessary whenever heavy bentonite leaks are detected from the opening under the head spacer. However, an indication of estimated component replacement intervals is present in the table in Fig. 14 in chapter 11 of the *Use and maintenance manual*. It is plausible to think that the state of wear of the components will be strongly correlated with the type of fluid and the percentage of the presence of solid residues.

To extract the piston seal, bring the entire unit to Top Dead Centre and operate as follows:

- A) Remove the front cover as indicated in Fig. 17.
 B) Remove the front plugs by means of an M12 extractor hammer.
 C) Unscrew the M8 screws on the piston unit and remove them together with the seal fastening bush (Fig. 23).
 D) Using an M12 cover screw, tighten using a T-handle wrench on the seal support so that it acts as an extractor (Fig. 23/a). After this, once the seat has come out, extract the pack, composed of the support and the piston seal (Fig. 24).



Fig. 23



Fig. 23/a

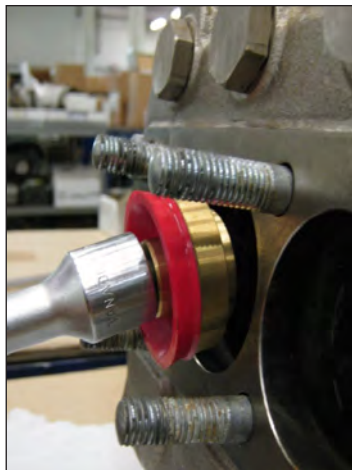

Fig. 24



The O-ring present on the seal support should be replaced at each disassembly.

2.2.4.2 Reassembly

- A) Assemble the piston seal with the seal support (on which the O-ring will be replaced), the seal fastening bush and the M8 screw (Fig. 25).

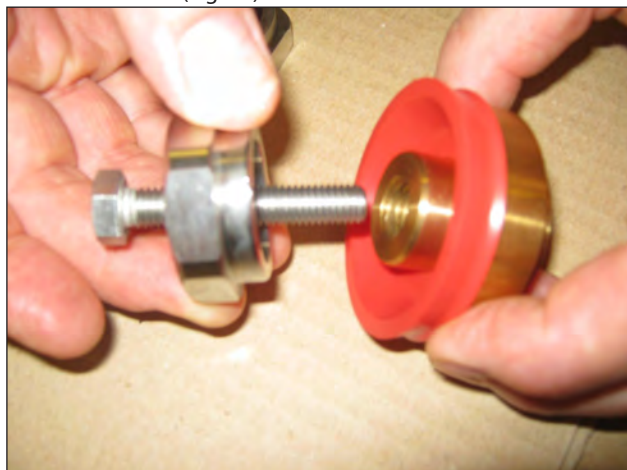

Fig. 25

- B) Lubricate the piston seal with abundant OCILIS 250 silicone grease code 12001600 (Fig. 26).



Fig. 26

- C) With the aid of a T-handle wrench, insert the piston seal pack inside the cylinder (Fig. 27) with the piston spacer unit at TDC, taking care not to damage the seal lip. Screw the M8 screws in so that the seal pack positions itself in the seat and tighten it with the tightening torque contained in chapter 3.



Fig. 27

2.2.5 Cylinder

2.2.5.1 Disassembly

Cylinder replacement is necessary whenever consistent bentonite leaks are detected from the opening under the head spacer. It is plausible to think that the state of wear of the component will be strongly correlated with the type of fluid and the percentage of the presence of solid residues.

Proceed as follows to extract the liner:

- A) Remove the front cover as indicated in Fig. 17 and unscrew the M12 screws as indicated in Fig. 17/a.
 B) Separate the head from the pump casing (Fig. 28) and extract the liner (Fig. 29), with the aid of adjustable pliers, and the relative seal (Fig. 30).



Fig. 28



Fig. 29



Fig. 30

2.2.5.2 Reassembly

To replace the cylinder and the head, proceed as follows:

- A) Insert the seals (Fig. 31) and the cylinders (Fig. 32) in the cylinder seat on the head.



Fig. 31



Fig. 32

- B) Assemble the head. Values of the tightening torques and sequences are contained in chapter 3.

3 COMPONENT TIGHTENING TORQUE

Description	Exploded view pos.	Material	Tightening torque Nm
Cover Fixing Screw	40	8.8	10
Piston Fixing	13	STAINLESS STEEL A2	20
Con-Rod Cap Fixing Screw	47	12 R	30*
Head fixing nut - Cover	30	8.8	80**
Head Fixing Screw	29	8.8	80**
Stud Bolt M12	31	8.8	80**
Screw Fix. Cov. Valves - frt.	21	8.8	80***
Stud Bolt M7	27	C 40	20****
Piston Spacer	22	STAINLESS STEEL	20
Screw Fix. Lifting Bracket	46	8.8	40
Plug G 1/2"	16	Nickel-Plated Brass	40
Plug G 1"	9	Zinc-Plated Steel	100

- * The con-rod cap fixing screws must be tightened respecting the phases indicated in Point D of pag. 16.
- ** The head fixing screws and nuts exploded view pos. 29 must be tightened with a torque wrench, lubricating the threaded shank, respecting the order shown in the diagram in Fig. 34.
- *** The cover fixing screws and nuts exploded view pos. 21 and 30 must be tightened with a torque wrench, lubricating the threaded shank, respecting the order shown in the diagram in Fig. 34.
- **** The stud bolt M7 exploded view pos. 27, is to be mounted on the spacer exploded view pos. 22 with Loctite 243 code 12006400.

Fig. 33

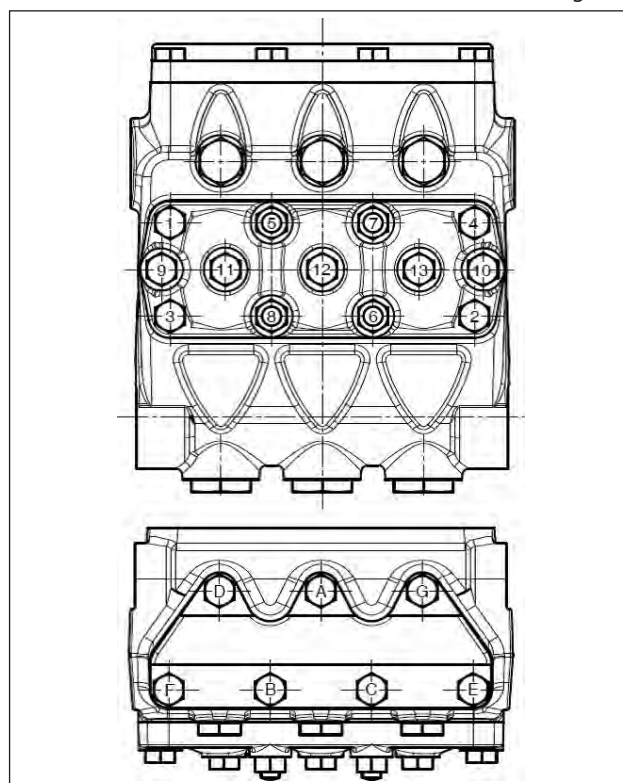

Fig. 34

4 REPAIR TOOLS

Pump repairs can be facilitated by special tools coded as follows:

For assembly phases:

Valve seat assembly tool (see par. 4.1)	code 27702200
Buffer for pump shaft oil seal	code 27904800
Buffer for piston guide oil seal	code 27904900

For disassembly phases:

Suction/outlet Valve seats (see par. 4.1)	Code 27922400
Suction and outlet valve plug	Extractor hammer
Piston guide oil seal	code 27503900



For proper assembly of the valve seats and relative disassembly, use tools code 27702200 and code 27922400.

4.1 VALVE SEAT ASSEMBLY / DISASSEMBLY TOOL MECHANICAL DRAWINGS.

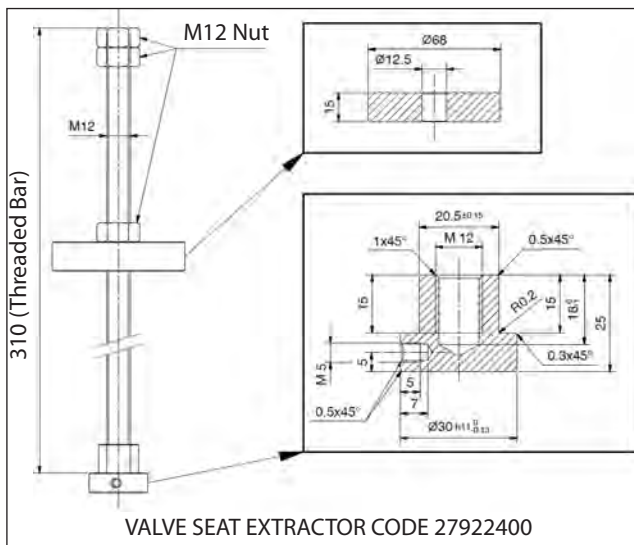
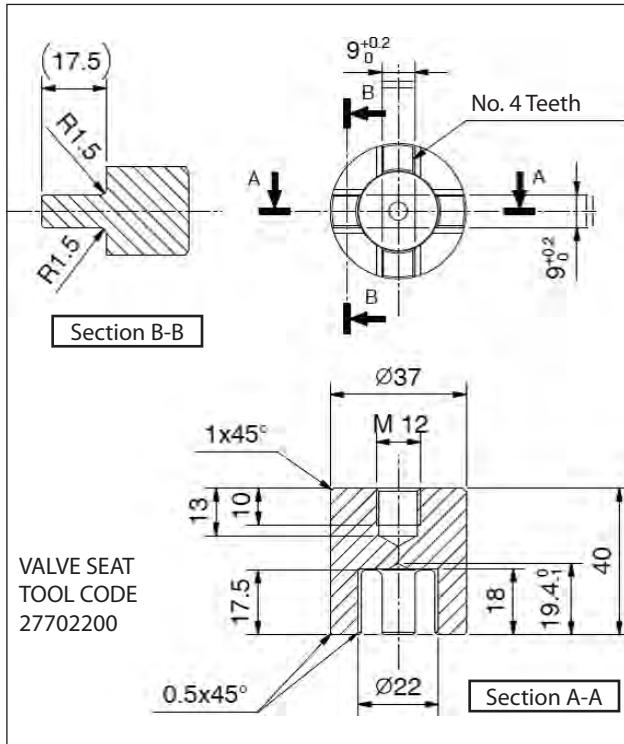



Copyright di queste istruzioni operative è di proprietà di Interpump Group.

Le istruzioni contengono descrizioni tecniche ed illustrazioni che non possono essere elettronicamente copiate e neppure riprodotte interamente od in parte né passate a terzi in qualsiasi forma e comunque senza l'autorizzazione scritta dalla proprietà. I trasgressori saranno perseguiti a norma di legge con azioni appropriate.

Copyright of these operating instructions is property of Interpump Group.

The instructions contain technical descriptions and illustrations which may not be entirely or in part copied or reproduced electronically or passed to third parties in any form and in any case without written permission from the owner. Violators will be prosecuted according to law with appropriate legal action.

D'après les lois de Copyright, ces instructions d'utilisation appartiennent à Interpump Group.

Les instructions contiennent des descriptions techniques et des illustrations qui ne peuvent être ni copiées ni reproduites par procédé électronique, dans leur intégralité ou en partie, ni confiées à des tiers sous quelque forme que ce soit, en l'absence de l'autorisation écrite du propriétaire. Les transgresseurs seront poursuivis et punis par la loi.

Copyright-Inhaber dieser Betriebsanleitung ist Interpump Group.

Die Anleitung enthält technische Beschreibungen und Abbildungen, die nur mit vorheriger schriftlicher Genehmigung des Copyright-Inhabers elektronisch kopiert, zur Gänze oder teilweise reproduziert oder in jeglicher Form an Dritte weitergegeben werden dürfen. Bei Verstößen drohen Rechtsfolgen.

El copyright de estas instrucciones operativas es propiedad de Interpump Group.

Las instrucciones contienen descripciones técnicas e ilustraciones que no pueden ser copiadas electrónicamente ni reproducidas de modo parcial o total, así como pasadas a terceras partes de cualquier forma y sin la autorización por escrito de la propiedad. Los infractores serán procesados de acuerdo a la ley con las medidas adecuadas.

Os direitos autorais destas instruções operacionais são de propriedade da Interpump Group.

As instruções contêm descrições técnicas e ilustrações que não podem ser eletronicamente copiadas ou reproduzidas inteiramente ou em parte, nem repassar a terceiros de qualquer forma sem autorização por escrito da proprietária. Os infratores serão processados de acordo com a lei, com as ações apropriadas.

Авторские права на данные инструкции по эксплуатации принадлежат компании Interpump Group.

Инструкции содержат технические описания и иллюстрации, которые не подлежат электронному копированию, а также не могут целиком или частично воспроизводиться или передаваться третьим лицам в любой форме без письменного разрешения владельца. Нарушители будут преследоваться по закону с применением соответствующих санкций.

I dati contenuti nel presente documento possono subire variazioni senza preavviso.

The data contained in this document may change without notice.

Les données contenues dans le présent document peuvent subir des variations sans préavis.

Änderungen an den in vorliegendem Dokument enthaltenen Daten ohne Vorankündigung vorbehalten.

Los datos contenidos en el presente documento pueden sufrir variaciones sin previo aviso.

Os dados contidos no presente documento podem estar sujeitos a alterações, sem aviso prévio.

Данные, содержащиеся в этом документе, могут быть изменены без предварительного уведомления.



3 Hôtel-de-Ville,
Dollard-des-Ormeaux, QC
Canada H9B 3G4

E info@fordia.com
P 514-336-9211
TF 1-800-768-7274
fordia.com