

SILEA

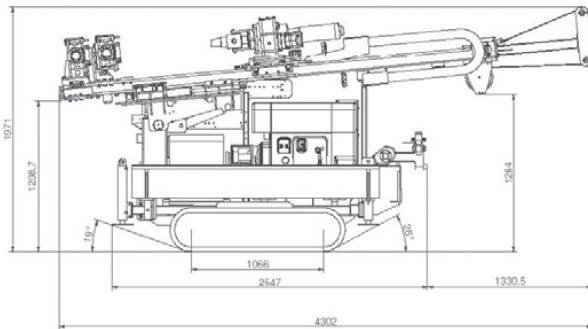

- Remote radio controlled track
- Hydraulic sliding of rotation head
- Fully automatic with injection swivel, single or double rod clamp and manipulation winch
- CE certified



Dimensions on displacement position

Length: 4,302 mm (14.11 ft)
 Width: 1,050 mm (3.44 ft)
 Height: 1,971 mm (6.46 ft)

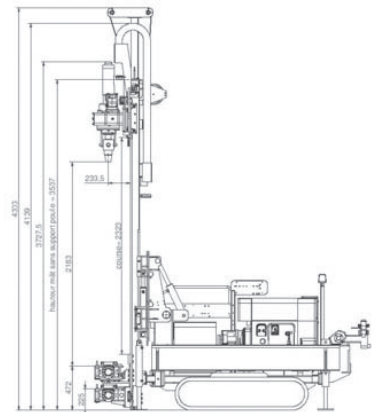

Dimensions on working position

Length: 2,950 mm (9.68 ft)
 Width: 1,050 mm (3.44 ft)
 Height: 4,303 mm (14.11 ft)

The **SILEA** is a compact and versatile drilling rig, designed for geotechnical investigation and environmental drilling.

Its 50 HP soundproof diesel engine, small dimensions and wide range of equipment options make it the perfect choice for site investigation, even in areas with difficult access.

The rotation/percussion head is equipped with two hydraulic motors and a hydraulic hammer, providing a wide range of torques and rotation speeds.

As a mid-range drilling rig, the SILEA gives you flexibility with its many accessories and options, including: triplex injection pump, single or double rod holder with unscrewing extraction cylinder providing 4 tons of capacity, handling winch, hydraulic erasing rotary head, semi-automatic or automatic hammering for SPT and DPSH and hammering core barrel.

It is CE certified and is equipped with all the necessary emergency stops and safeties to protect operators.

WEIGHT

	METRIC	IMPERIAL
TOTAL (DEPENDING ON OPTIONS)	2,000 to 2,500 kg	4,409 to 5,512 lb

CHASSIS

DESCRIPTION
Mechanically welded steel skid
4 hydraulic stabilization jacks

MAST

	DESCRIPTION
LENGTH	2,100 - 2,500 - 3,500 mm
FEED	Reduction motor and chain
PULL-BACK CAPACITY	2,500 kg (5,512 lb)
PUSH-DOWN THRUST	1,500 kg (3,307 lb)
DRILLING DIAMETER	200 mm max.
MAST HYDRAULIC TRANSLATION	300 mm

ROTATION HEAD

	DESCRIPTION
HYDRAULIC MOTORS	Danfoss (2x)
MAX. TORQUE	0 to 190 daNm
MAX. SPEED	0 to 260 rpm
PERCUSSION FORCE	220 joules/blow
PERCUSSION FREQUENCY	1,200 bpm
INJECTION SWIVEL	Air/water
THREADS	Male 2"3/8 IF and Female R38

TRACK

	DESCRIPTION
TRACK	Remote radio controlled - fixed or adjustable width
WIDTH	780 to 1,050 mm

POWER PACK

	DESCRIPTION
SOUND PROOF HATZ	50 HP
FUEL TANK	35 L
OIL TANK	90 L
PUMP	Triple - fixed capacity
DISTRIBUTORS	Danfoss PVG 32

OPTIONS

	DESCRIPTION
WATER INJECTION PUMP	80 L/min - 40 bars
MANIPULATION WINCH	500 kg
ROTATION HEAD	Hydraulic sliding
ROD CLAMP	Simple or double - 170 mm
EXTRACTION JACK	Capacity 4,000 kg

